

## TECHNICAL SPECIFICATIONS

Measurement principle	Raman Spectroscopy
Components	C1..C5+, H <sub>2</sub> , N <sub>2</sub> and CO <sub>2</sub>
Number of lasers	Single laser, single stream measurement
Sample wetted parts	SS316
Electronics housing / protection	Epoxy coated stainless steel / aluminum (IP65)
Cell Housing / protection	Epoxy coated stainless steel (IP65)
Sample temperature	Up to 80°C (176°F)
Sample pressure	Low pressure 10-75 barG (145...1087 psig)
Sample flow	Non-critical, flow depends on process parameters such as pressure, flow and density
Communication	1x MODBUS RTU over RS485 1x MODBUS TCP/IP over Ethernet 1x MODBUS TCP/IP over optical fiber (option)
Digital outputs	Potential free, 1 x analyzer fault, 3x free programmable
Hazardous area	ATEX Ex II 2G Ex op pr pxb IIC T3 Gb (Raman electronics cabinet) ATEX Ex II 2G Ex db eb op pr IIC T3 Gb (Raman probe cabinet) ATEX Ex II 2G Ex db IIC T5 Gb (Raman signal isolation box) IECEX Ex op pr pxb IIC T3 Gb (Raman electronics cabinet) IECEX Ex db eb op pr IIC T3 Gb (Raman probe cabinet) IECEX Ex db IIC T5 Gb (Raman signal isolation box) Class I Div 2 Gr. B,C,D T3 (Raman electronics cabinet) Class I Div 2 Gr. B,C,D T3 (Raman probe cabinet) NEPSI Ex op pr pxb IIC T3 Gb (Raman electronics cabinet) NEPSI Ex db eb op pr IIC T3 Gb (Raman probe cabinet) NEPSI Ex db IIC T5 Gb (Raman signal isolation box)
Ambient conditions	Standard -20°C ... 40°C / -4 ... 104°F Optional -20°C ... 55°C / -4 ... 130°F
Utilities	Power: 110/230 VAC, 50/60Hz (max 1200W) Dry instrument air: 5Nl/min
Dimensions spectrometer box	Depending on execution 800x500x400mm (HxWxD)
Dimensions probe box	Depending on execution 600x600x300mm (HxWxD)
Repeatability <sup>1</sup>	
Individual components:	Better than +/- 0,5% F.S.
Calculated parameters:	Better than +/- 0,5% F.S.
Accuracy <sup>2</sup>	
Individual components:	Better than +/- 1% F.S.
Calculated parameters:	Better than +/- 0,5% F.S.
Response time (T90)	Typical 10s (Including sample system lag time and independent of process pressure)

<sup>1</sup>Based on 20 barG sample pressure and 30 sec moving average.

<sup>2</sup>Based on 20 barG sample pressure and 30 sec moving average.

<sup>3</sup>Response time depends on moving average. Rapid composition changes are detected in 10s.



**Headquarters**  
Netwerk 4  
1446 WK Purmerend  
The Netherlands

**USA Sales & service**  
8468 North Sam Houston Pkwy West  
Houston, TX 77064  
The United States

+31 299 420871  
Info@hobre.com

+1 832 404 2760  
infousa@hobre.com

For additional specifications, please refer to the general brochure of [WWW.HOBRE.COM](http://WWW.HOBRE.COM)



07-2024

CUSTOMIZED DESIGN TO POWER A LIFETIME OF VALUE



[www.hobre.com](http://www.hobre.com)

# HOBRE PRISM

RAMAN SPECTROSCOPY GAS ANALYZER

ZERO EMISSION ANALYZER CONCEPT

*"Fast responding and zero emission gas composition analysis for feed forward control."*



CUSTOMIZED DESIGN TO POWER A LIFETIME OF VALUE

[www.hobre.com](http://www.hobre.com)

In corporation with TNO (the Netherlands Organization for applied scientific research) in Delft, Hobr  developed a very robust and innovative, patented Raman technology for online gas analysis in the oil and gas industry, including renewables. With the Raman technology Hobr  offers a fast responding gas composition analysis for feed forward control on high- and low-pressure applications. The combination between the Hobr  Raman technology and Hobr 's proprietary HIFISC probe design results in an unmatched Zero-Emission setup.

## FEATURES

- Complete natural gas (incl. H<sub>2</sub>) analysis in 10 seconds.
- Non-destructive measurement. Analyzed sample is returned to process.
- No pressure reduction required. High pressure has a positive effect on the Raman signal.
- Flow and pressure independent.
- High pressure and temperature flow cell for analysis at process conditions.
- Separation between sample and electronics by use of optical fibers.
- No need for frequent calibrations.

## Principle of Operation

The Hobr  Raman can simultaneously measure C1..C5+, N<sub>2</sub>, H<sub>2</sub>, CO<sub>2</sub> in gases. Technologically wise, the Hobr  Raman is a big step forward as it offers a combination of features not available in any other analyzer on the market, e.g.:

- High accuracy compositional analysis in 10 seconds,
- No moving parts,
- Full separation of detector and electronics,
- Wide concentration range,
- Zero-emission design,
- Lowest lag time and nearly zero dead volume,
- Suitable for high pressure application, without the need for pressure reduction,
- Close to zero maintenance and low spare component costs,
- Hydrogen measurement as a standard (0-100% range) makes it "future proof",
- Output of physical properties like heating value, Wobbe Index, density, specific gravity, heat ratio Cp/Cv, compressibility, air demand.

## Technology

The analysis is based on the Raman measurement principle and named after its discoverer, the physicist C.V. Raman. Raman spectroscopy is a nondestructive, fast responding measurement principle that provides chemical information on the sample being analyzed. This technique allows users to obtain (near) real time information on the composition as well as physical properties which can be used to optimize efficiency based on a feedforward control loop.

Light interacts with materials in different ways (transmitting, reflecting or scattering). Raman looks at scattered light. A continuous wave type laser is focused into a measuring cell through a spherical lens. The scattered light is detected by a spectrometer. Most of the light that scatters remain unchanged in energy (Rayleigh Scattered). A small fraction of the scattered light will lose or gain energy. This fraction is referred to as Raman scattering.

The change in energy depends on the vibration frequency of the molecule. Light atoms have strong bonds and a high frequency, resulting in a significant change in energy. Heavy elements (low frequency, weak bonds) show a small change in energy. The energy difference between the two states is unique and can be used for both identification of an element and quantitative analysis.

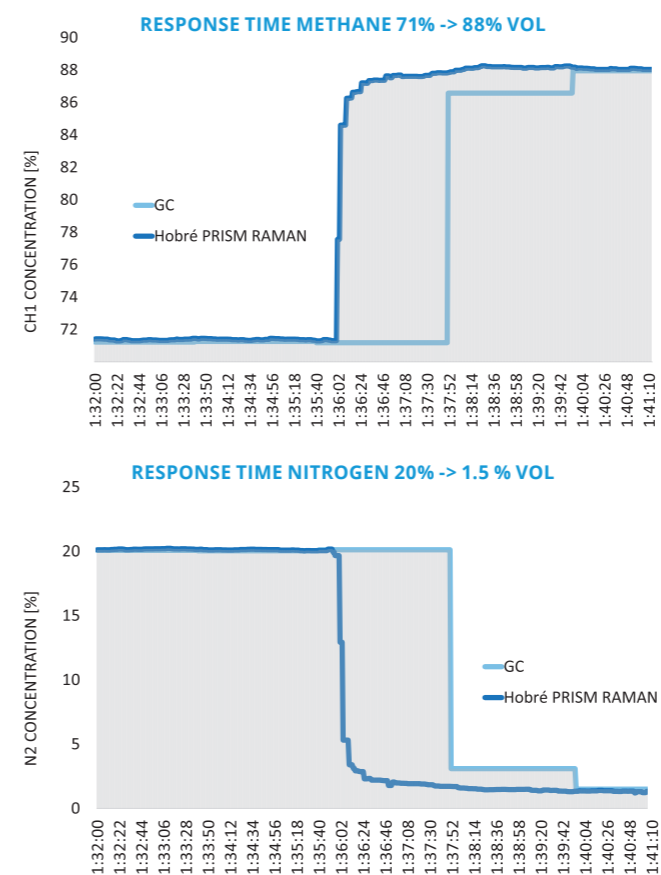

## Installation

The Raman analyzer operates on process pressure. This simplifies the installation and offers the following advantages.

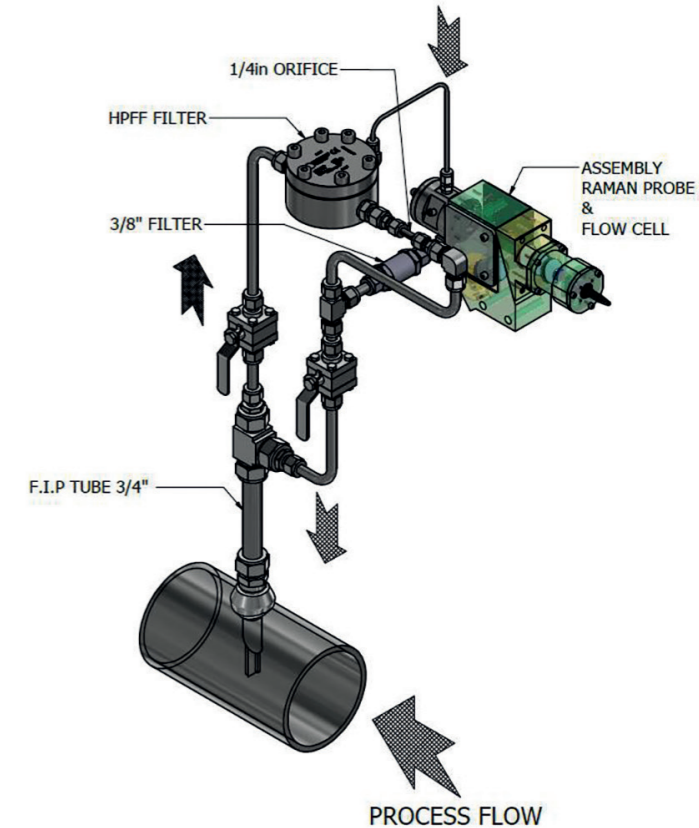

1. No need to reduce the pressure (which would require heated regulators).
2. Sample is returned to process, eliminating the need for large fast loop flows and venting to atmosphere or flare.
3. The probe design allows for the shortest possible lag time and a nearly zero dead volume.

Hobr  offers the Raman analyzer in combination with the HIFISC sample technology. The differential pressure over the probe tip of the HIFISC probe, drives a fast loop over a multiphobic filter element. A small amount of sample is guided through the measuring cell for analysis. The complete sample flow is returned to process.

