

SUPCON

# SUPCON Radar Level Transmitter Selection Guide



SUPCON TECHNOLOGY CO.,LTD.  
ZHEJIANG SUPCON INSTRUMENT CO.,LTD.

**01**

Company Profile

**03**

Production Capability

**06**

SL903 Series



**12**

SL902 Series

**19**

SL901 Series



# PRODUCTION

---

## Production Ability

**73000** SUPCON Industrial Park covers an area of over 73,000 m<sup>2</sup>

In October 2018, SUPCON intelligent manufacturing plant was relocated to Fuyang industrial park. Fuyang industrial park phase I takes up to a total area of 73,000 square meters, capable of producing 2.5 million modules and 30,000 cabinets per year. The park embodies advanced automation equipment such as PCBA production line, automatic coating production line, and self-developed functional test (FCT) production line. In the key quality control section, the park has SPI, X-Ray, AOI and other testing equipment. In terms of warehousing and logistics, the park is equipped with AGV, automatic silo and intelligent drying cabinet and other equipment.



Intelligent Production Line

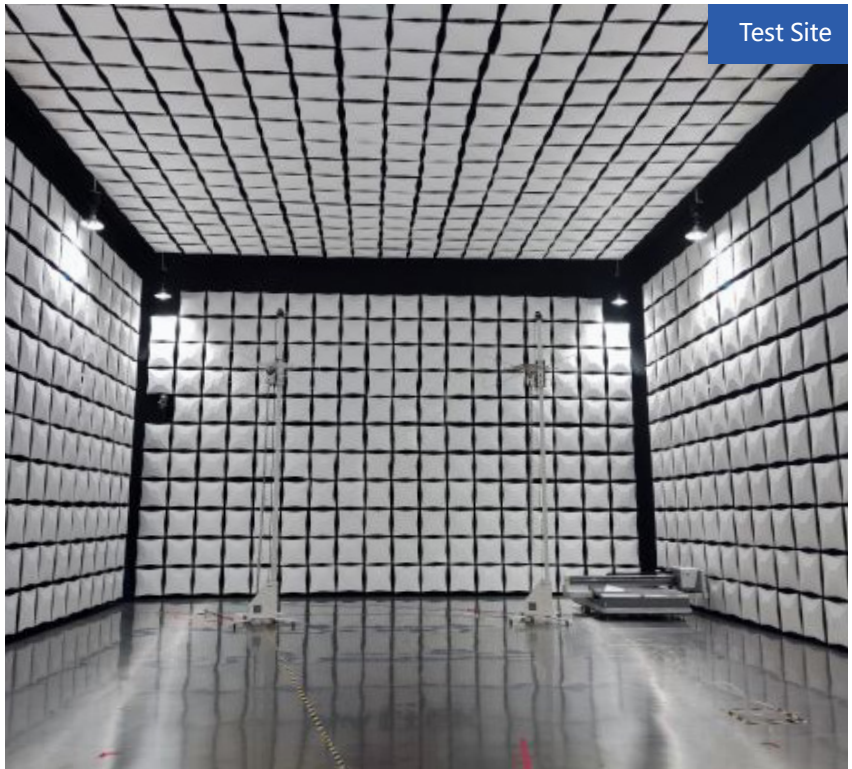
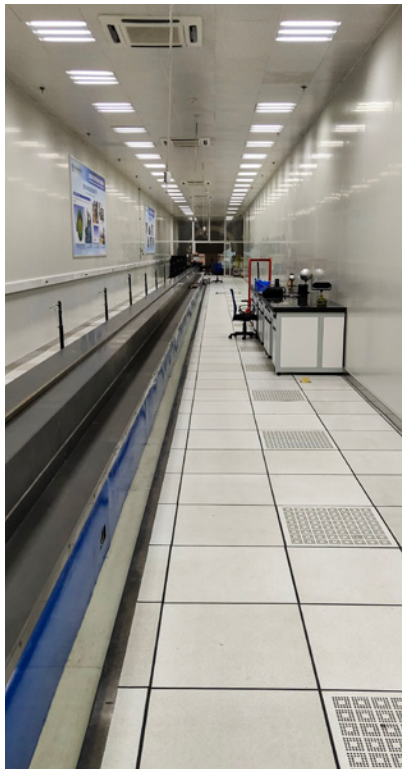

# SL903 Series

80GHz Radar Level Transmitter





## 01 | Overview

SL903 series 80GHz radar level meter is a high-frequency radar level measurement instrument, with millimetre wave band, smaller beam angle, more concentrated energy, stronger penetration, and advanced intelligent echo tracking processing technology, which can continuously measure the level of liquid, slurry and granular materials in a non-contact way. The product is high temperature resistant, high pressure resistant, non-contact, suitable for various metal and non-metal containers, reactors or solid silos and other working environments. It can withstand the harsh working conditions of reactors and stirred tanks, easy to install and debug, and is nearly unaffected by any changes in media properties including density, PH and viscosity.



## 02 | Measuring Principle

Radar level meter through the antenna transmits a FMCW (Frequency Modulated Continuous Wave) signal, the microwave signal propagates in space at the speed of light, and is reflected back after contacting the surface of the measured medium and is received by the antenna system. The signal is amplified, filtered and other pre-processing, then sampled by the AD to get a digital signal, then sent to the processor for data processing, and finally calculated to get the distance of the measured target. Finally, the distance of the measured target is calculated.

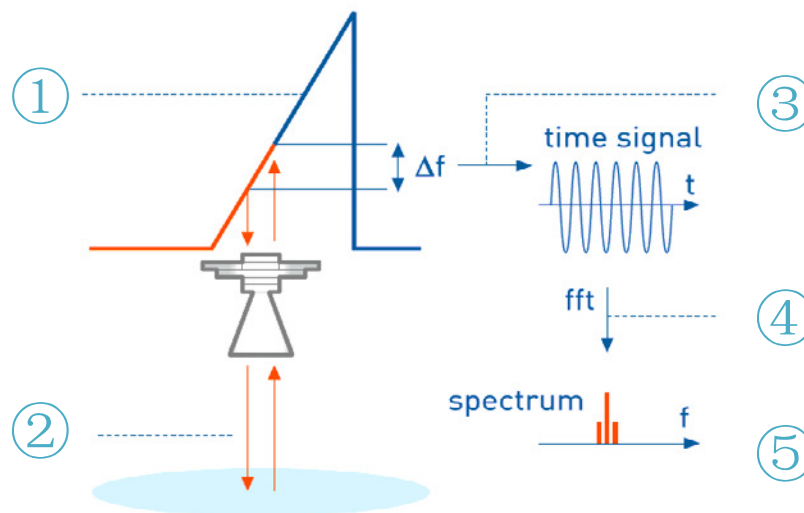

Figure 1

- ① Emits modulated continuous electromagnetic waves.
- ② Electromagnetic waves propagate downwards and reflect when they meet a medium.
- ③ There is a frequency difference between the reflected echo and the modulated electromagnetic waveform.
- ④ Digital Signal Processing (Fast Fourier Transform).
- ⑤ Calculate the level value.



## 03 | Product Features

- ▶ Non-contact level measurements.
- ▶ Beam angles as small as 3° for measurements in confined spaces or waveguide ducts.
- ▶ Excellent signal-to-noise ratio (SNR) for better echo quality.
- ▶ Millimetre-band radar with more concentrated energy and better penetration capability.
- ▶ FMCW (Frequency Modulated Continuous Wave) high-bandwidth measurements for greater accuracy.
- ▶ (4~20)mA standard current output, HART bus protocol communication.
- ▶ 160x80 dot-matrix LCD backlit liquid crystal display.
- ▶ Rich echo processing algorithms and empirical data adaptation for various working environments.
- ▶ Special material and anti-corrosion coating design, full structure sealing, long-term reliable operation.



## 04 | Technical Parameters

### 4.1 Technical Parameters Table

Table 1:

SL903 Series Radar Level Transmitter			
Appearance			
Model No.	SL903-5		
Antenna Type	Lens	Lens	Lens
Process Connection	Flange DN50	Flange DN80	Flange DN100
Emission Frequency	80GHz		
Range	10m/20m/70m/100m		
Display Accuracy	±1mm		
Wetted Parts	304/316/PTFE/PEEK		
Process Pressure	(-0.1~3)MPa		
Process Temperature	(-40~230)°C		
Signal Output	(4~20)mA HART		
Power Supply	24VDC 2-Wire/4-Wire		
Local Display	160x80 Auto-Backlit LCD		
Protection Degree	IP66/IP67		
Ex Approval	Exia IIC T6 Ga/Exd IIC T6 Gb		



## 5.1 SL903 Model Selection

Table 2:

<b>Antenna Type</b>	<b>Explosion</b>
5 Lens	00 Standard type (non-explosion-proof)
Z Customized	N1 (Exd IIC T6 Gb)
<b>Process Connection</b>	N2 (Exia IIC T6 Ga)
S1 Thread G1 1/2"	<b>Power &amp; Output</b>
S2 Thread G3 1/2"	20 2-wired 24VDC , (4~20)mA HART
F0 Flange DN50 (2")	40 4-wired 24VDC , (4~20)mA ,HART
F1 Flange DN65 (2.5")	41 4-wired 24VDC , RS485
F2 Flange DN80 (3")	60 2-wired 24VDC , (4~20)mA ,HART, tank side monitor and 2" bracket
F3 Flange DN100 (4")	ZZ Customized
F4 Flange DN125 (5")	<b>Housing</b>
F5 Flange DN150 (6")	A Single chamber aluminum housing , M20*1.5
F6 Flange DN200 (8")	B Double chamber aluminum housing , M20*1.5
F7 Flange DN250 (10")	C Single chamber aluminum housing , ½NPT
W2 Flange DN80 (3")+ Swivelling holder	D Double chamber aluminum housing, ½NPT
W3 Flange DN100 (4")+ Swivelling holder	E Single chamber 316 housing , M20*1.5
ZZ Customized	F Single chamber 316 housing , ½NPT
<b>Add-on</b>	Z Customized
0 None	<b>Display And Operation</b>
1 With purging connection	1 Glass Window Cover
<b>Pressure Rating</b>	2 Glass Window with dustproof cover
0 None	3 Blind cover (open to display)
1 PN10/16	Z Customized
2 PN25/40	<b>Range</b>
3 Class150	01 10 metres
4 Class300	02 20 metres
Z Customized	07 70 metres
<b>Temperature Range</b>	10 100 metres
V (-40~130)°C	ZZ Customized
K (-40~230)°C	<b>Additional Options</b>
Z Customized	Empty
<b>Wetted Parts Material</b>	Y1 With Test report
1 304	Y2 With SIL2 certificate
2 316	Y3 With tank side monitor cable (note length)
3 PTFE	Y4 With SPD
4 304+PTFE	Y5 Companion flange
5 316+PTFE	ZZ Other
Z Customized	



## 06 | Outline Dimensions

6.1

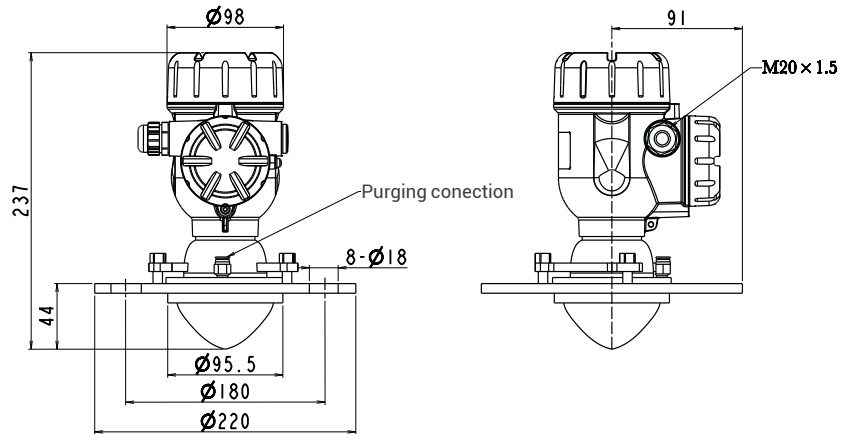

Figure 2

6.2

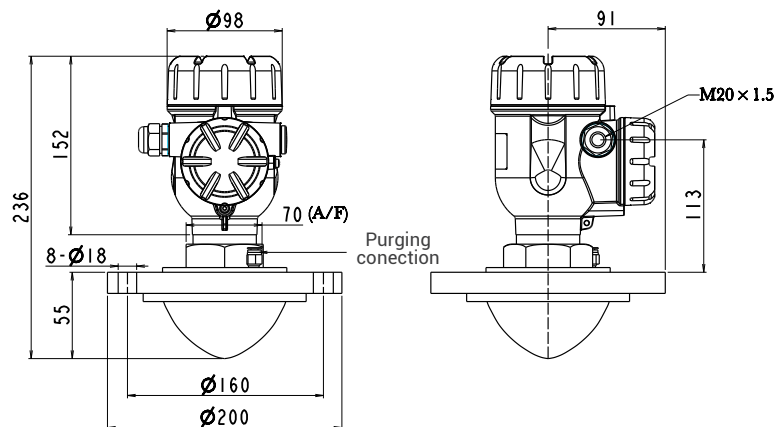

Figure 3



## 7.1 Typical Installation

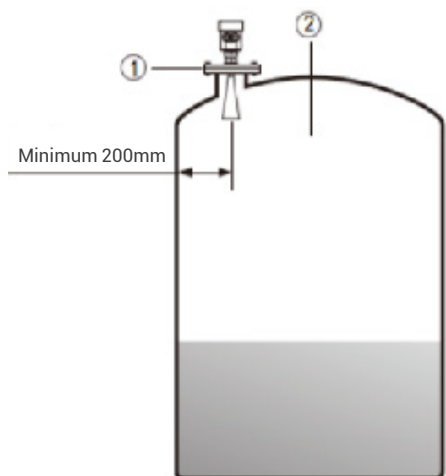

Figure 4

Figure 4: In typical installation, should be installed at 1/4 or 1/6 of the tank diameter.

Note: Minimum distance from the wall of the tank is at least 200mm.

① Reference Level ② Center of vessel or its symmetry axis.

## 7.2 Conical Tank



Figure 5

Figure 5: For such conical vessel with flat roof, should be installed at the center of its roof, as the effective measurement can reach the bottom of vessel.

## 7.3 Solids Storage Tanks

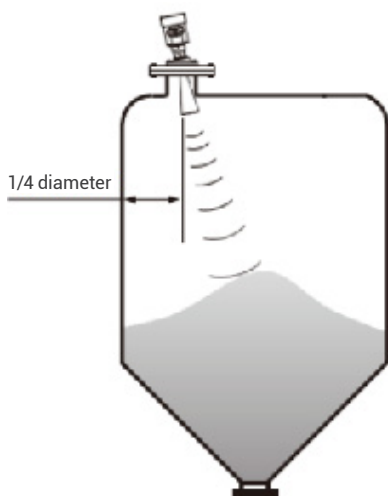

Figure 6

Figure 6: For such solids storage tank, align the antenna so that it is perpendicular to the media surface; if the surface is not flat and the stack angle is large, should use the universal flange to adjust the horn angle so that the horn can aim at the material surface. (Because the inclined solids surface would cause echo decay and even signal loss)

# SL902 Series

26GHz Radar Level Transmitter



## 01 | Overview

SL902 Series 26GHz Radar Level Transmitter is a high frequency radar level measurement instrument. With the mature manufacturing process, multiple options of process connection, customized components and advanced intelligent echo tracking management technology, it enables non-contact continuous level measurement of the liquid, slurries and solids. As it is resistant to high temperature and high pressure as well as its non-contact structure, it can be applied in a variety of metallic and non-metallic vessels, reactors, solids silos and etc. The product can withstand harsh working conditions in the reactors and mixing tanks, as it is not only easy to do installation and commissioning, but also hardly be affected by any media characteristics change including the density, PH and viscosity.

## 02 | Measuring Principle

The radar level meter emits extremely narrow microwave signals through an RF circuit, which are transmitted downwards through an antenna. The microwave propagates at the speed of light in space, contacts the surface of the measured medium, and is reflected back and received by the antenna system. The signal is preprocessed by amplification, filtering, etc., then sampled by AD to obtain a digital signal, which is sent to the processor for data processing. Finally, the distance of the measured target is calculated.

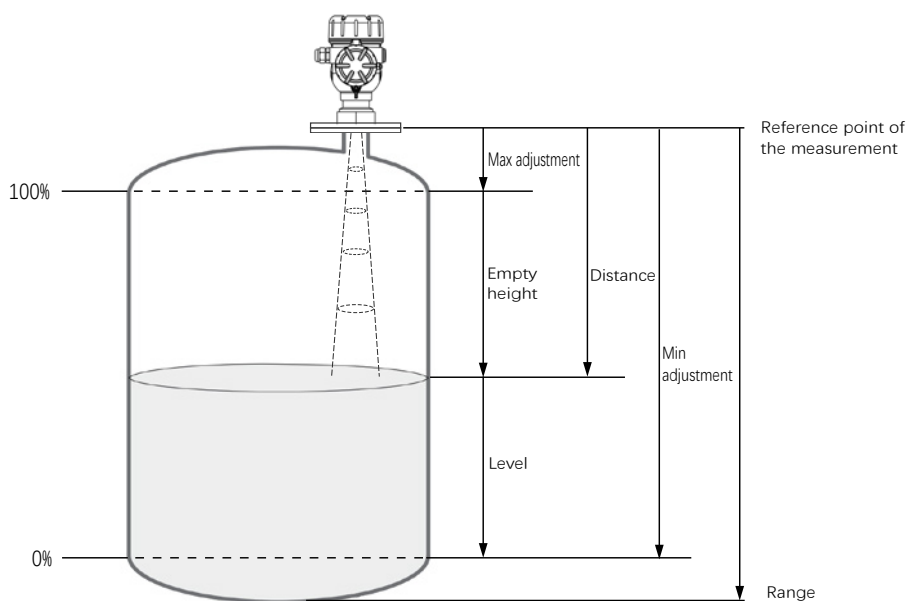

Figure 1



## 03 | Product Characteristics







- ▶ Non-contact level measurement.
- ▶ Various antenna shapes available for common level measurement.
- ▶ Excellent signal-to-noise ratio (SNR) and better echo quality.
- ▶ Wider detection range and better diffraction performance.
- ▶ (4~20) mA standard current output, HART protocol communication.
- ▶ 160x80 dot-matrix backlit LCD display.
- ▶ Multi-echo tracking algorithms and rich application data compatible with various working conditions.
- ▶ Special material and anti-corrosion coating design, full sealing structure and long & reliable service time.



## 04 | Technical Parameters

### 4.1 Technical Parameters of Table

Table 1:

SL902 Series Radar Level Transmitter							
Appearance							
Model No.	SL902-0	SL902-1	SL902-2	SL902-3	SL902-4	SL902-5	SL902-6
Antenna Type	Horn	Planar	Paraboloid	Rod	Droplet	Lens	Anti-corrosion sleeve
Process Connection	Flange or G1 ½" Thread	Flange	Flange or G1 ½" Thread	Flange or G1 ½" Thread	Flange	Flange	Flange
Frequency	26GHz						
Range	30m/70m						
Display Accuracy	±1mm						
Wetted Parts	304/316/PTFE/PEEK						
Process Pressure	(-0.1 ~ 4)MPa						
Process Temperature	(-40 ~ 230)°C						
Signal Output	(4~20)mA HART						
Power Supply	24VDC 2Wire /4Wire						
Local Display	160*80 Auto-Backlit LCD						
Protection Degree	IP66/IP67						
Ex Approval	Exia IIC T6 Ga/Exd IIC T6 Gb						



## 5.1 SL902 Model Selection

Table 2:

Antenna Type	
0 Horn	4 Droplet
1 Planar	5 Lens
2 Paraboloid	6 Anti-corrosion sleeve
3 Rod	Z Customized
Process Connection	
S1 Thread G 1 ½"	
F0 Flange DN50 (2")	
F1 Flange DN65 (2.5")	
F2 Flange DN80 (3")	
F3 Flange DN100 (4")	
F4 Flange DN125 (5")	
F5 Flange DN150 (6")	
F6 Flange DN200 (8")	
F7 Flange DN250 (10")	
W2 Flange DN80 (3")+ Swivelling holder	
W3 Flange DN100 (4")+ Swivelling holder	
ZZ Customized	
Add-on	
0 None	
1 With purging connection	
2 With dust cover (horn type)	
Pressure Rating	
0 None	3 Class150
1 PN10/16	4 Class300
2 PN25/40	Z Customized
Temperature Range	
V (-40~130)°C	
K (-40~230)°C	
Z Customized	
Wetted Parts Material	
1 304	
2 316	
3 PTFE	
4 304+PTFE	
5 316+PTFE	
Z Customized	

Explosion	
00 Standard type (non-explosion-proof)	
N1 (Exd IIC T6 Gb)	
N2 (Exia IIC T6 Ga)	
Power & Output	
20 2-wired 24VDC , (4~20)mA HART	
40 4-wired 24VDC , (4~20)mA ,HART	
41 4-wired 24VDC , RS485	
60 2-wired 24VDC , (4~20)mA ,HART, tank side monitor and 2" bracket	
ZZ Customized	
Housing	
A Single chamber aluminum housing , M20*1.5	
B Double chamber aluminum housing , M20*1.5	
C Single chamber aluminum housing , ½NPT	
D Double chamber aluminum housing , ½NPT	
E Single chamber 316 housing , M20*1.5	
F Single chamber 316 housing , ½NPT	
Z Customized	
Display And Operation	
1 Glass Window Cover	
2 Glass Window with dustproof cover	
3 Blind cover (open to display)	
Z Customized	
Range	
03 30 metres	
07 70 metres	
ZZ Customized	
Additional Options	
Empty	
Y1 With Test report	
Y2 With SIL2 certificate	
Y3 With tank side monitor cable (note length)	
Y4 With SPD	
Y5 Companion flange	
ZZ Other	



## 06 | Outline Dimensions

### 6.1 SL902-0

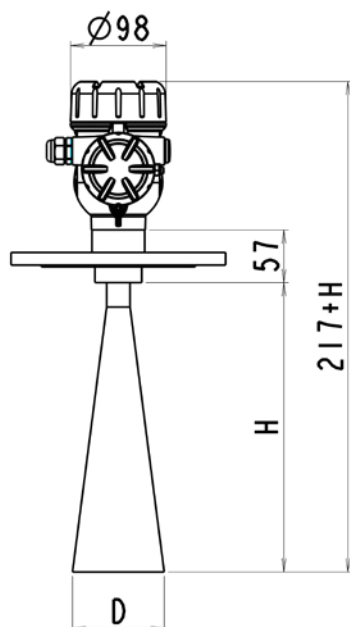

Flange	D	H
DN50	$\varnothing 46$	140
DN80	$\varnothing 76$	227
DN100	$\varnothing 96$	288

Figure 2

### 6.2 SL902-1

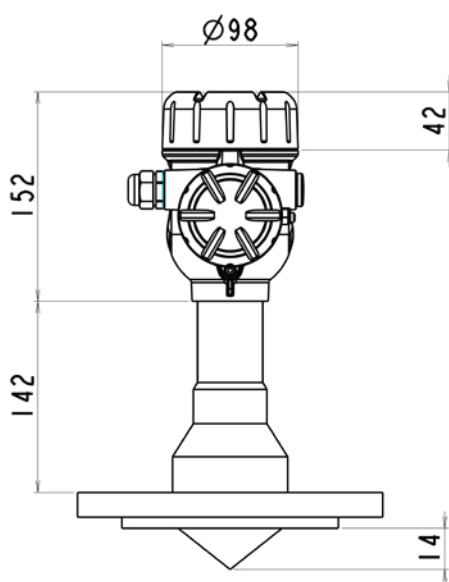

Figure 3

### 6.3 SL902-2

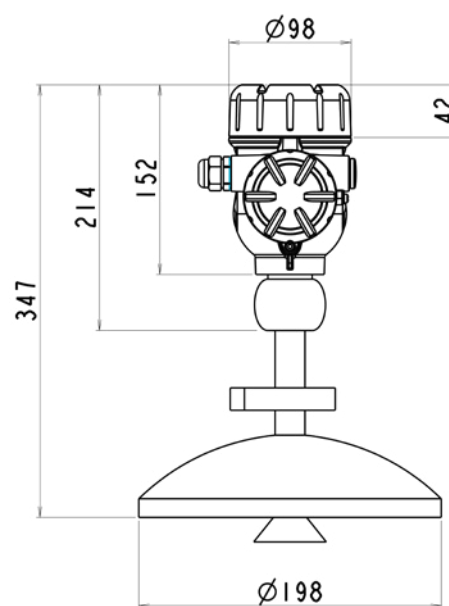

Figure 4

### 6.4 SL902-3

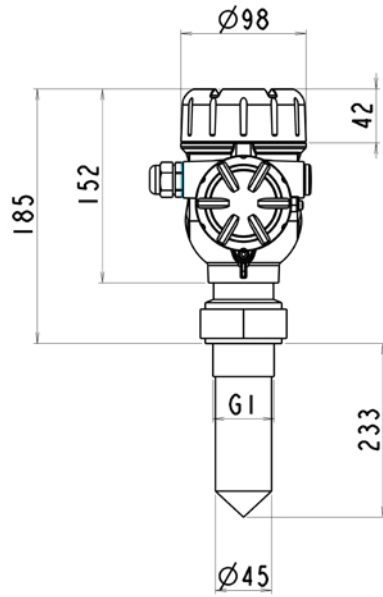

Figure 5

### 6.5 SL902-4

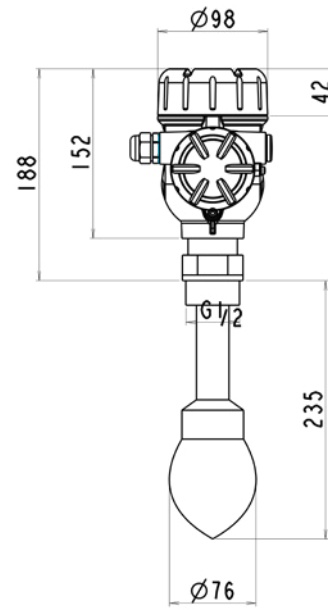

Figure 6

### 6.6 SL902-5

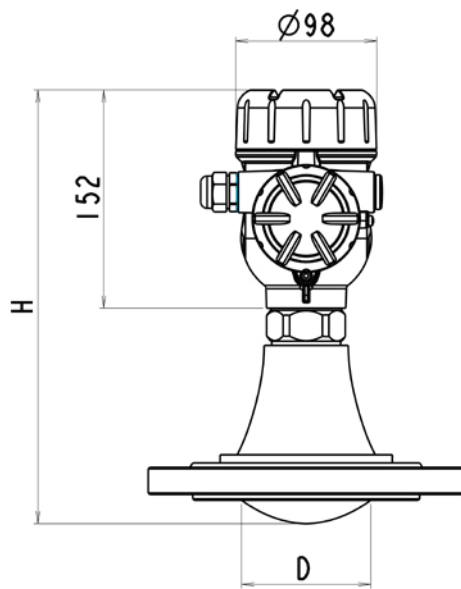

Figure 7

### 6.7 SL902-6

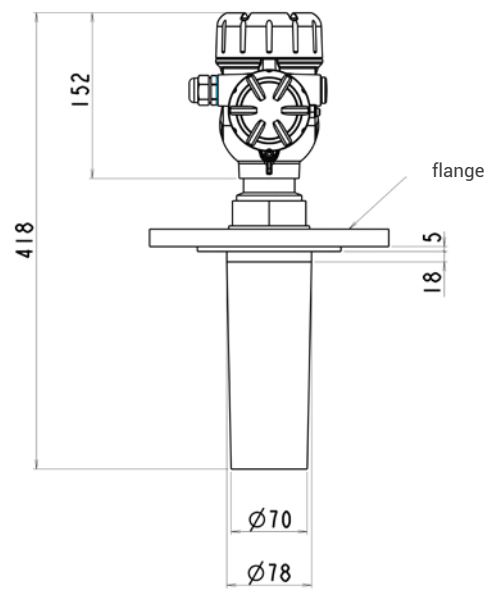

Figure 8



## 7.1 Typical Installation

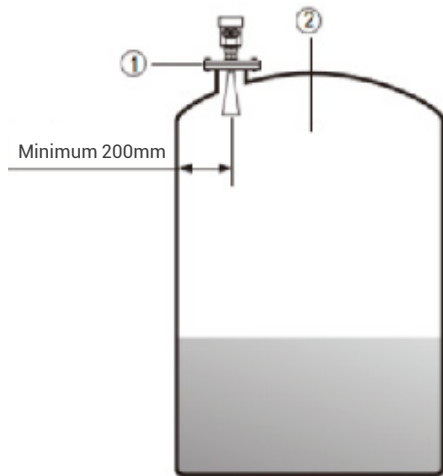

Figure 9

Figure 9: In typical installation, should be installed at 1/4 or 1/6 of the tank diameter.

Note: Minimum distance from the wall of the tank is at least 200mm.

① Reference Level ② Center of vessel or its symmetry axis.

## 7.2 Conical Tank

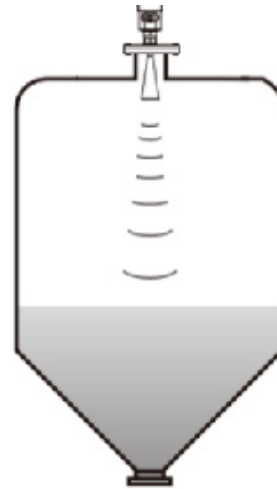

Figure 10

Figure 10: For such conical vessel with flat roof, should be installed at the center of its roof, as the effective measurement can reach the bottom of vessel.

## 7.3 Solids Storage Tanks

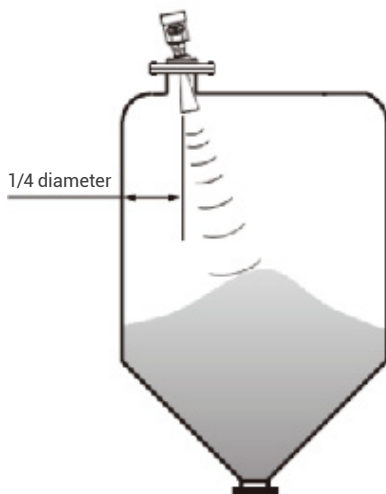
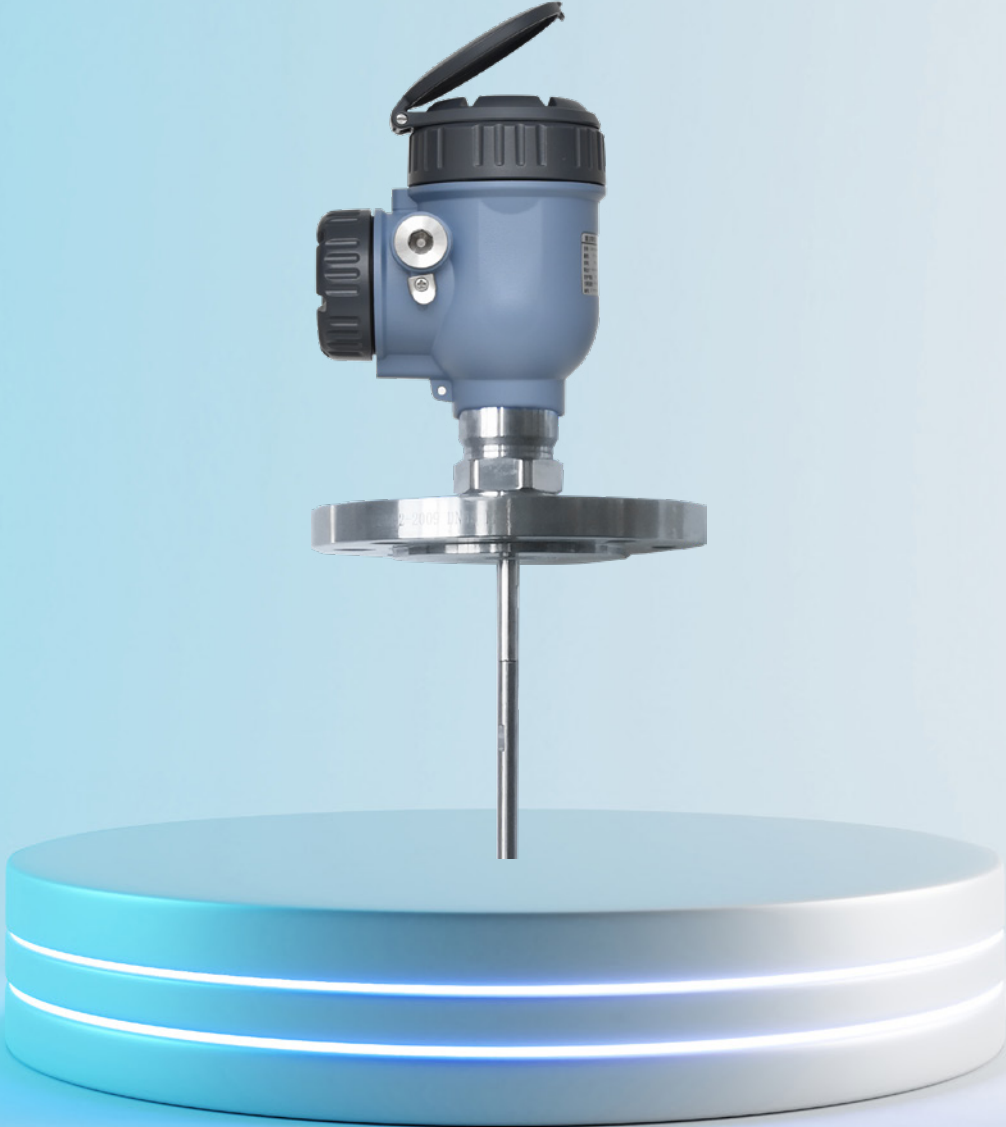

Figure 11

Figure 11: For such solids storage tank, align the antenna so that it is perpendicular to the media surface; if the surface is not flat and the stack angle is large, should use the universal flange to adjust the horn angle so that the horn can aim at the material surface. (Because the inclined solids surface would cause echo decay and even signal loss)

# SL901 Series

Guided Wave Radar Level Transmitter





## 01 | Overview

SL901 series guided wave radar level meter adopts advanced microprocessor and unique choDiscovery echo processing technology, with a variety of process connections and detection components, suitable for a variety of complex conditions and applications, especially for high temperature and high pressure and small dielectric constant medium. The guided wave radar level meter adopts pulse working mode, with very low emission power, and can be installed in all kinds of metal and non-metal containers, which is harmless to human body and environment.



## 02 | Measuring Principle

Guided-wave radar emits high-frequency microwave pulses that propagate along the detection component (guided-wave rod or guided-wave cable), and when it encounters the measured medium, due to the sudden change of dielectric constant, it causes reflection, and a part of the pulse energy is reflected back. The time interval between the emitted pulse and the reflected pulse is proportional to the distance of the measured medium, and the polarity and amplitude of the echo depends on the upper medium and the dielectric constant of the lower medium.

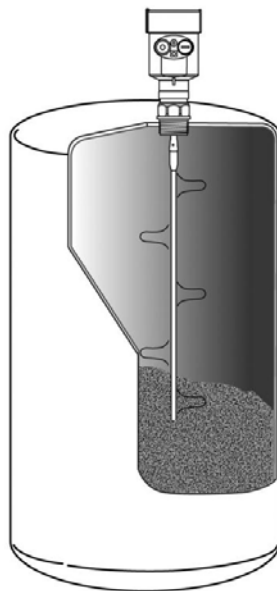

Figure 1



## 03 | Product Characteristics



- ▶ Rod, rope or coaxial contact level measurement.
- ▶ More stable measurement of fluctuating media.
- ▶ More suitable for measuring materials in small tanks.
- ▶ Less affected by dielectric constant.
- ▶ Highly resistant to interference, measurements are not affected by vapours or foam.
- ▶ (4~20)mA standard current output, HART bus protocol communication.
- ▶ High resolution LCD liquid crystal display.
- ▶ Rich echo processing algorithms and empirical data adaptation for various working environments.
- ▶ Special material and anti-corrosion coating design, full structure sealing, long-term reliable operation.



## 04 | Technical Parameters

### 4.1 Technical Parameters Table

Table 1:

SL901 Series Radar Level Meter							
Appearance							
Model No.	SL901-0	SL901-1	SL901-2	SL901-3	SL901-4	SL901-5	SL901-6
Antenna Type	∅ 8mm Rod	∅ 10mm Rod	∅ 16mm Rod	∅ 4mm Rope	∅ 8mm Rope	∅ 22mm Coaxial	∅ 42mm Coaxial
Process Connection	Threaded / Flange						
Range	6m			30m		3m	
Display Accuracy	±5mm						
Process Pressure	(-0.1~4)MPa						
Process Temperature	(-40~230)°C						
Signal Output	(4~20)mA HART						
Power Supply	24V DC						
Protection Degree	IP66/IP67						
Ex Approval	Exia IIC T6 Ga/Exd IIC T6 Gb						



## 5.1 SL901 Model Selection

Table 2

Antenna Type
0 Rod 8mm
1 Rod 10mm
2 Rod 16mm
3 Rope 4mm
4 Rope 8mm
5 Coaxial 22mm
6 Coaxial 42mm
Z Customized
Process Connection
S1 Thread G 1 1/2"
F0 Flange DN50 (2")
F1 Flange DN65 (2.5")
F2 Flange DN80 (3")
F3 Flange DN100 (4")
F4 Flange DN125 (5")
F5 Flange DN150 (6")
F6 Flange DN200 (8")
F7 Flange DN250 (10")
ZZ Customized
Pressure Rating
0 None
1 PN10/16
2 PN25/40
3 Class150
4 Class300
Z Customized
Temperature Range
V (-40~130)°C
K (-40~230)°C
Z Customized
Wetted Parts Material
1 304
2 316
4 304+PTFE
5 316+PTFE
6 304+PFA
7 316+PFA
8 304+PVC
9 316+PVC
Z Customized

Explosion
00 Standard type (non-explosion-proof)
N1 (Exd IIC T6 Gb)
N2 (Exia IIC T6 Ga)
Power & Output
20 2-wired 24VDC , (4~20)mA HART
40 4-wired 24VDC , (4~20)mA , HART
41 4-wired 24VDC , RS485
60 2-wired 24VDC , (4~20)mA , HART, tank side monitor and 2" bracket
ZZ Customized
Housing
A Single chamber aluminum housing , M20*1.5
B Double chamber aluminum housing , M20*1.5
C Single chamber aluminum housing , 1/2NPT
D Double chamber aluminum housing , 1/2NPT
E Single chamber 316 housing , M20*1.5
F Single chamber 316 housing , 1/2NPT
Z Customized
Display And Operation
1 Glass Window Cover
2 Glass Window with dustproof cover
3 Blind cover (open to display)
Z Customized
Range
XX Range: 01 to 30 , indicating (1 to 30) metres
ZZ Customized
Additional Options
Empty
Y1 With Test report
Y2 With SIL2 certificate
Y3 With tank side monitor cable (note length)
Y4 With SPD
Y5 Companion flange
ZZ Other



## 06 | Outline Dimensions

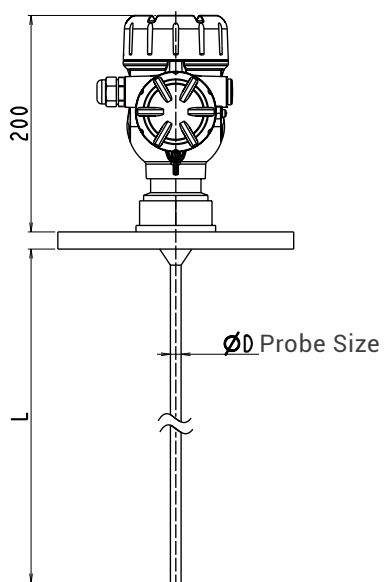

Figure2 Rod

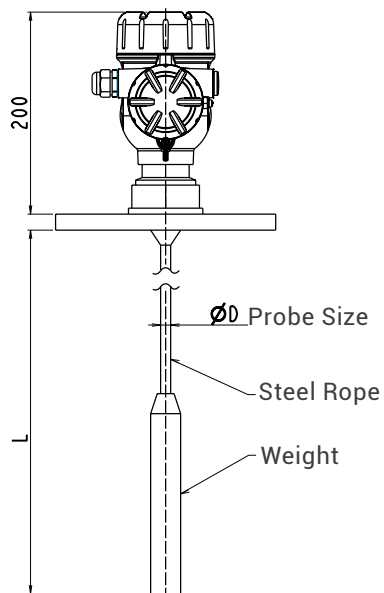

Figure3 Rope

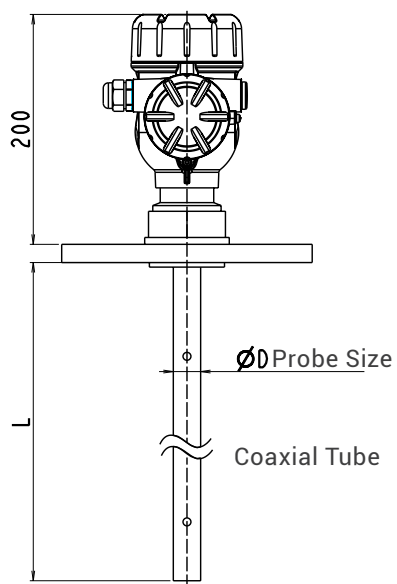

Figure3 Coaxial rod



## 07 | Installation Requirements

### 7.1 Typical Installation

- ▶ Keep away from the outlet and inlet as much as possible.
- ▶ Metal cans do not touch the walls and bottom of the can throughout the range .
- ▶ It is recommended to install at 1/4 or 1/6 of the bin diameter with a minimum distance from the tank wall of 1/10 of the measuring range.
- ▶ Minimum distance from the tank wall for cable or rod probes  $\geq 300\text{mm}$ .
- ▶ The bottom of the probe is  $\geq 30\text{mm}$  from the bottom of the tank.
- ▶ Minimum distance of the probe from obstacles in the tank  $\geq 200\text{mm}$ .
- ▶ If the bottom of the vessel is tapered, the centre of the tank top can be installed.

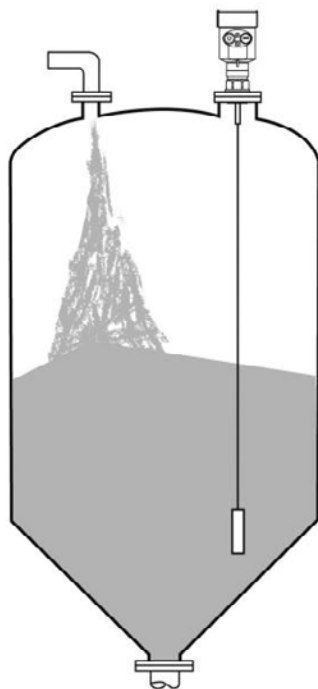

Figure 4

**SUPCON TECHNOLOGY CO.,LTD.**  
**ZHEJIANG SUPCON INSTRUMENT CO.,LTD.**

---

Add: SUPCON Park, No.309 Liuhe Road, Binjiang District, Hangzhou 310053, China

Tel: +86-571-8111-8759

Fax: +86-571-8666-7318

Email: [overseas@supcon.com](mailto:overseas@supcon.com)

Web: <https://www.supconauto-en.com>