

WeldMate

Collaborative Robot

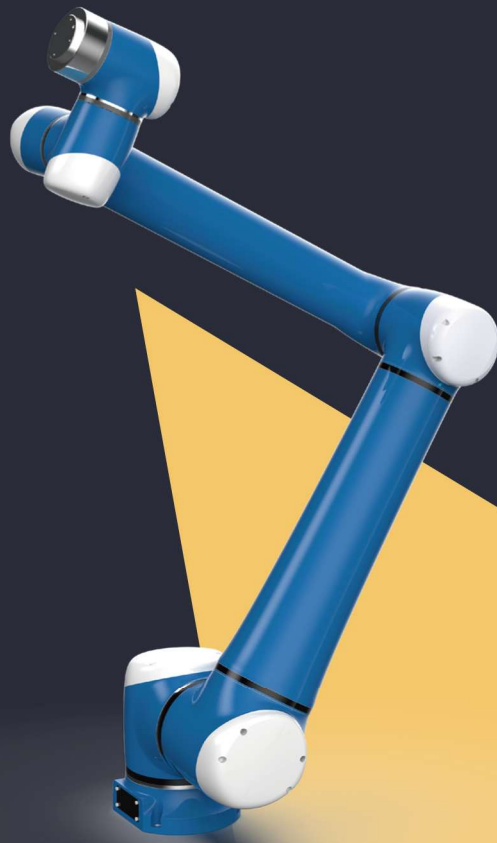

Robotic Welding Solutions:

WM-1310

WM-905

Designed for versatility, this advanced power tool sets new benchmarks in collaborative robotics. Its quick deployment and user-friendly interface enable rapid problem-solving across diverse industrial scenarios.

User-Friendly, Safe and Highly Integrated



Highly Integrated

Control and program multiple devices—across different vendors and brands—through a single, unified platform.



User-friendly

The intuitive interface ensures high accessibility and a time- and cost-efficient integration, ideal for small batch sizes or highly flexible applications.



Safe

Our robots meet the highest safety standards and provides cutting-edge safety functions to cooperate seamlessly with humans.

A World-First Joystick Controller

Program welding tasks effortlessly in under a minute — no coding, just buttons.

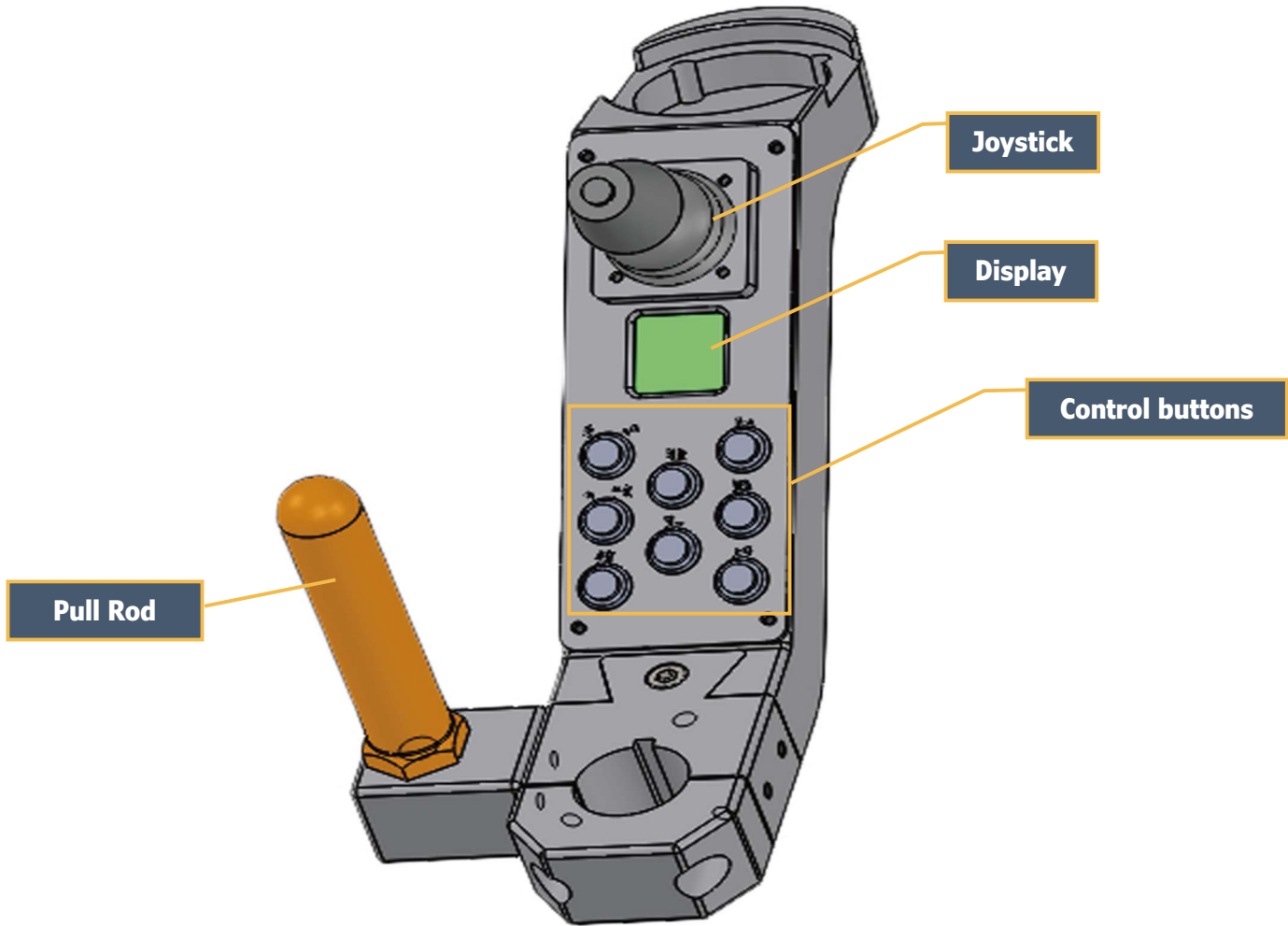

Control buttons

Welding task programming can be done through user-friendly button-based controls

Joystick

Swing up, down, left, right, forward/backward (twisting) to control the robot arm and speed adjustment

Pull Rod

Your choice to install freely on either the left or right side to suit both life- and right-handed operation

Display

Display of speed, XYZ/ABC motion, welding and oscillation parameters

User-friendly Operation

Supports drag-to-move functionality, allowing rapid large-distance positioning near the weld point. The uniquely designed end-effector enables fast programming without the need for a teaching pendant.

UPS

Features a built-in Uninterruptible Power Supply (UPS) for power failure protection and task regeneration.



Enables gravity compensation with real-time detection of tool payloads to ensure stable and accurate operation.



Dual encoder configuration ensures higher reliability and secure position feedback for critical applications.



Supports arc tracking to automatically adjust the welding path in real time based on weld seam deviations*.



Equipped with collision sensing and instant stop capability for safe and efficient human-robot interaction.

Features with * are available as optional add-ons and are subject to additional charges. Please contact francis@weldmate.com.au for further information and quote.

Build-in Procedure Packages

Multi-pass, Multi-layer Welding

Supports customised welding angles and multi-layer configurations



Weave Welding

Supports multiple patterns including C-Weave, Circular Weave, Zig Zag and Tree-Weave, etc.

Automatic Weld Seam Detection*

Integrable laser sensors scan the workpiece to precisely locate the weld path



Arc Tracking*

Integrable sensor enabling real-time adjustment to ensure precise weld paths even with part variations or misalignments

Specifications

WM-1310



Number of Axes	6	
Load	10kg	
Operating Radius	1320mm	
Repeated Positioning Accuracy	±0.02mm	
Absolute Precision	≤ 0.3mm	
Joints	Max Angle of each Axis	Max Joint Velocity
1	±360°	107°/S
2	±360°	107°/S
3	-78°~256°	200°/S
4	±360°	250°/S
5	±360°	250°/S
6	±360°	250°/S
End Button	2 buttons	Drag and mark
End I/O port	4 ports	Four digital inputs and outputs
Breathing Light	1 light	
Towing Apparatus	1 set	6 programming buttons: ARC, MOVL, Toggle (XYZ/ABC) MOV, RES, MOVJ
Rocker	1 set	Arbitrary direction
Environmental Conditions	Temperature: 0~45°, humidity: 20%~80%(no frost and dew)	
Body Weight	Approx. 33kg	
Installation	Formal/upside down/wall mounted	
IP Code	IP54	

Specifications

WM-905



Number of Axes	6	
Load	5kg	
Operating Radius	900mm	
Repeated Positioning Accuracy	±0.02mm	
Absolute Precision	≤ 0.3mm	
Joints	Max Angle of each Axis	Max Joint Velocity
1	±360°	225°/s
2	±360°	225°/s
3	-75°~250°	225°/s
4	±360°	250°/S
5	±360°	250°/S
6	±360°	250°/S
End Button	2 buttons	Drag and mark
End I/O port	4 ports	Four digital inputs and outputs
Breathing Light	1 light	
Towing Apparatus	1 set	6 programming buttons: ARC, MOVL, Toggle (XYZ/ABC) MOVC, RES, MOVJ
Rocker	1 set	Arbitrary direction
Environmental Conditions	Temperature: 0~45°, humidity: 20%~80%(no frost and dew)	
Body Weight	Approx. 22kg	
Installation	Formal/upside down/wall mounted	
IP Code	IP54	

Weldmate – EzWeld Station

Customised Welding Station

Welding Table

Welding Machine

Other Accessories

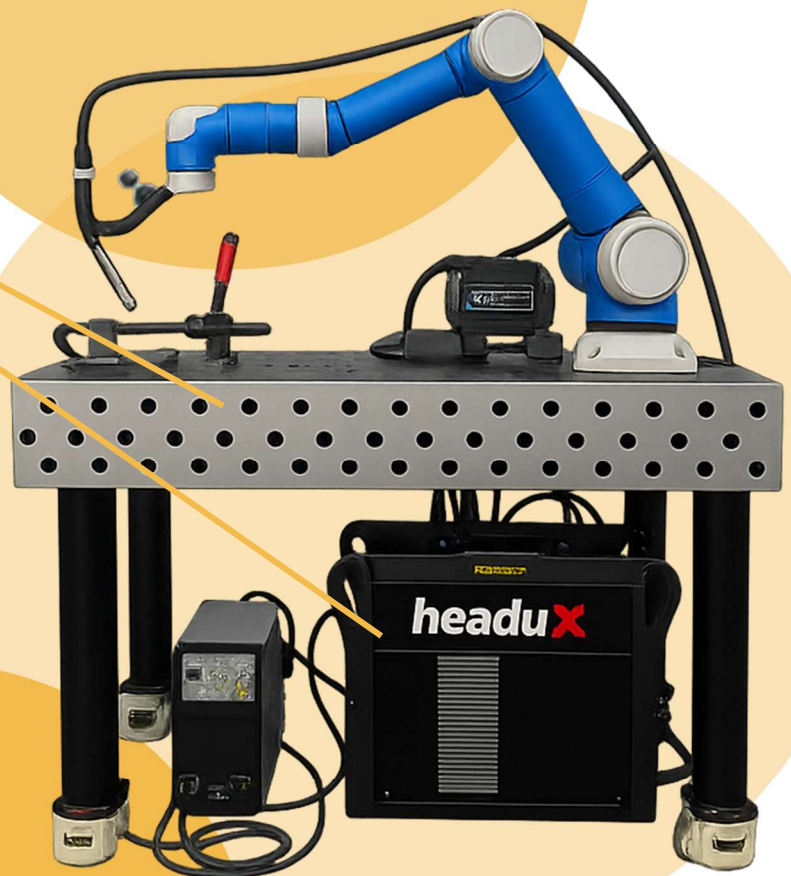

***Flexible package deal and individual product pricing are available upon request. Customised combination available.**

Get in touch with us for detailed information and a customised quotation.